

GEBRAUCHS- UND MONTAGEANLEITUNG
OPERATING AND INSTALLATION INSTRUCTIONS
NOTICE D'UTILISATION ET DE MONTAGE
GEBRUIKS- EN MONTAGEAANWIJZING
INSTRUKCJA OBSŁUGI I MONTAŻU
NÁVOD K POUŽITÍ A K MONTÁŽI
KEZELÉSI ÉS SZERELÉSI UTASÍTÁS
ИНСТРУКЦИЯ ПО МОНТАЖУ И ЭКСПЛУАТАЦИИ

OFFENER (DRUCKLOSER) WARMWASSERSPEICHER | OPEN (PRESSURELESS) WATER HEATER |
CHAUFFE-EAU OUVERT (A ÉCOULEMENT LIBRE) | OPEN (DRUKLOZE) WARMWATERBOILER |
POJEMNOŚCIOWE, BEZCIŚNIENIOWE OGRZEWACZE WODY | BEZTLAKOVÝ ZÁSOBNÍKOVÝ
OHŘÍVAČ TEPLÉ VODY | NYITOTT (NYOMÁS NÉLKÜLI) MELEGVÍZ TÁROLÓ | ОТКРЫТЫЙ
(БЕЗНАПОРНЫЙ) НАКОПИТЕЛЬНЫЙ ВОДОНАГРЕВАТЕЛЬ

- » SNU 10 SL comfort
- » SNU 10 SLi comfort

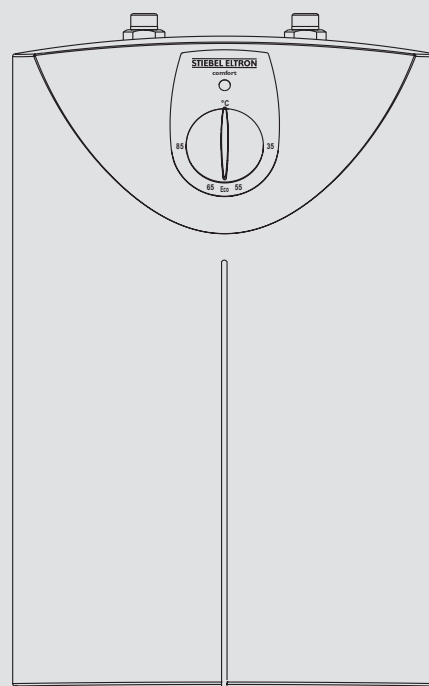

STIEBEL ELTRON

Technik zum Wohlfühlen

Inhaltsverzeichnis

1. Gebrauchsanleitung	4
1.1 Gerätebeschreibung	4
1.2 Das Wichtigste in Kürze	4
1.3 Bedienung	4
1.4 Wichtige Hinweise	4
1.5 Pflege und Wartung	4
1.6 Was tun wenn . . . ?	4
2. Montageanleitung	5
2.1 Geräteaufbau	5
2.2 Gerätebeschreibung	5
2.3 Technische Daten	5
2.4 Vorschriften und Bestimmungen	5
2.5 Wichtige Hinweise	5
2.6 Montageort	5
2.7 Gerätemontage	5
2.8 Erstinbetriebnahme	5
2.9 Servicehinweise	5
3. Störungsbeseitigung	6
4. Umwelt und Recycling	6
5. Kundendienst und Garantie	7

List of contents

1. Operating Instructions	8
1.1 Description of Unit	8
1.2 The most important points in brief	8
1.3 Operation	8
1.4 Important Note	8
1.5 Care and Maintenance	8
1.6 What to do if . . . ?	8
1.7 Special accessories	8
2. Installation Instructions	9
2.1 Unit Type	9
2.2 Description of Unit	9
2.3 Technical Data	9
2.4 Regulations and Conditions	9
2.5 Important Notes	9
2.6 Installation Site	9
2.7 Unit Installation	9
2.8 First Use	9
2.9 Service Notes	9
3. Fault Repair	10
4. Environment and recycling	10
5. Guarantee	10

Sommaire

1. Instructions d'utilisation	11
1.1 Description de l'appareil	11
1.2 Sommaire des informations essentielles	11
1.3 Utilisation	11
1.4 Observations importantes	11
1.5 Entretien et maintenance	11
1.6 Que faire si . . . ?	11
1.7 Accessoires spécifiques	11
2. Instructions de montage	12
2.1 Composants de l'appareil	12
2.2 Description de l'appareil	12
2.3 Caractéristiques techniques	12
2.4 Normes et réglementations	12
2.5 Remarque importante	12
2.6 Lieu de montage	12
2.7 Montage de l'appareil	12
2.8 Première mise en service	12
2.9 Instructions de maintenance	12
3. Dépannage	13
4. Environment et recyclage	13
5. Garantie	13

Inhoudsopgave

1. Gebruiksaanwijzing	14
1.1 Beschrijving van het toestel	14
1.2 In kort bestek	14
1.3 Bediening	14
1.4 Belangrijke instructies	14
1.5 Reiniging en onderhoud	14
1.6 Wat te doen, indien . . . ?	14
1.7 Speciale accessoires	14
2. Montageaanwijzing	15
2.1 Opbouw van het toestel	15
2.2 Beschrijving van het toestel	15
2.3 Technische gegevens	15
2.4 Voorschriften en bepalingen	15
2.5 Belangrijke instructies	15
2.6 Plaats van montage	15
2.7 Montage van het toestel	15
2.8 Eerste inbedrijfsname	15
2.9 Service-instructies	15
3. Verhelpen van storingen	16
4. Milieu en recycling	16
5. Garantie	16

Spis treści

1. Instrukcja obsługi	18
1.1 Opis urządzenia	18
1.2 Ważne wskazówki w skrócie	18
1.3 Obsługa	18
1.4 Ważna wskazówka	18
1.5 Konserwacja i czyszczenie	18
1.6 Co robić, gdy . . . ?	18
1.7 Sprzęt dodatkowy	18
2. Instrukcja montażu	19
2.1 Budowa urządzenia	19
2.2 Opis urządzenia	19
2.3 Dane techniczne	19
2.4 Przepisy i zalecenia	19
2.5 Ważne wskazówki	19
2.6 Miejsce montażu urządzenia	19
2.7 Montaż urządzenia	19
2.8 Pierwsze uruchomienie	19
2.9 Wskazówki serwisowe	19
3. Usuwanie usterek	20
4. Środowisko naturalne i recykling	20
5. Gwarancja	20

Obsah

1. Návod k použití	21
1.1 Popis přístroje	21
1.2 Nejdůležitější informace ve zkratce	21
1.3 Obsluha	21
1.4 Důležité pokyny	21
1.5 Ošetřování a údržba	21
1.6 Co dělat, když . . . ?	21
1.7 Zvláštní příslušenství	21
2. Instrukce k montáži	22
2.1 Konstrukce přístroje	22
2.2 Popis přístroje	22
2.3 Technická data	22
2.4 Předpisy a ustanovení	22
2.5 Důležité pokyny	22
2.6 Montážní místo	22
2.7 Montáž přístroje	22
2.8 První uvedení do provozu	22
2.9 Pokyny pro servis	22
3. Odstraňování závad	23
4. Ekologie a recyklace	23
5. Záruční podmínky	23

Tartalomjegyzék

1. Kezelési utasítás	24
1.1 A készülék leírása	24
1.2 A legfontosabbak röviden	24
1.3 Kezelés	24
1.4 Fontos figyelmeztetések	24
1.5 Tisztítás és karbantartás	24
1.6 Mit tegyenek, ha . . .	24
1.7 Kiegészítők	24
2. Szerelési utasítás	25
2.1 A készülék felépítése	25
2.2 A készülék leírása	25
2.3 Műszaki adatok	25
2.4 Előírások és meghatározások	25
2.5 Fontos figyelmeztetések	25
2.6 A felszerelés helye	25
2.7 A készülék felszerelése	25
2.8 Első üzembe helyezés	25
2.9 Szervízelőírások	25
3. Hibaelhárítás	26
4. Környezet és újrahasznosítás	26
5. Garancia	26

Содержание

1. Инструкция по эксплуатации	27
1.1 Описание прибора	27
1.2 Коротко о самом важном	27
1.3 Управление	27
1.4 Важные указания	27
1.5 Уход и техническое обслуживание	27
1.6 Что делать, если . . . ?	27
1.7 Специальные принадлежности	27
2. Инструкция по монтажу	28
2.1 Конструкция прибора	28
2.2 Описание прибора	28
2.3 Технические характеристики	28
2.4 Предписания и определения	28
2.5 Важные указания	28
2.6 Место монтажа	28
2.7 Монтаж прибора	28
2.8 Первый ввод в эксплуатацию	28
2.9 Указания по сервисному обслуживанию	28
3. Устранение неисправностей	29
4. Окружающая среда и вторсырьё	29
5. Гарантия	29

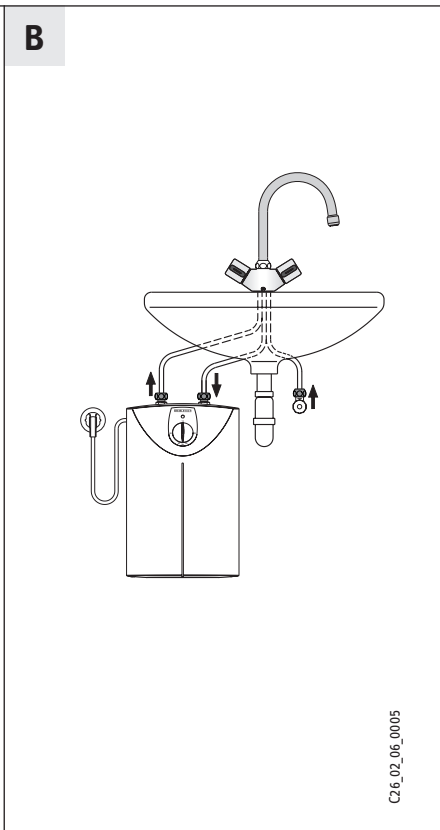
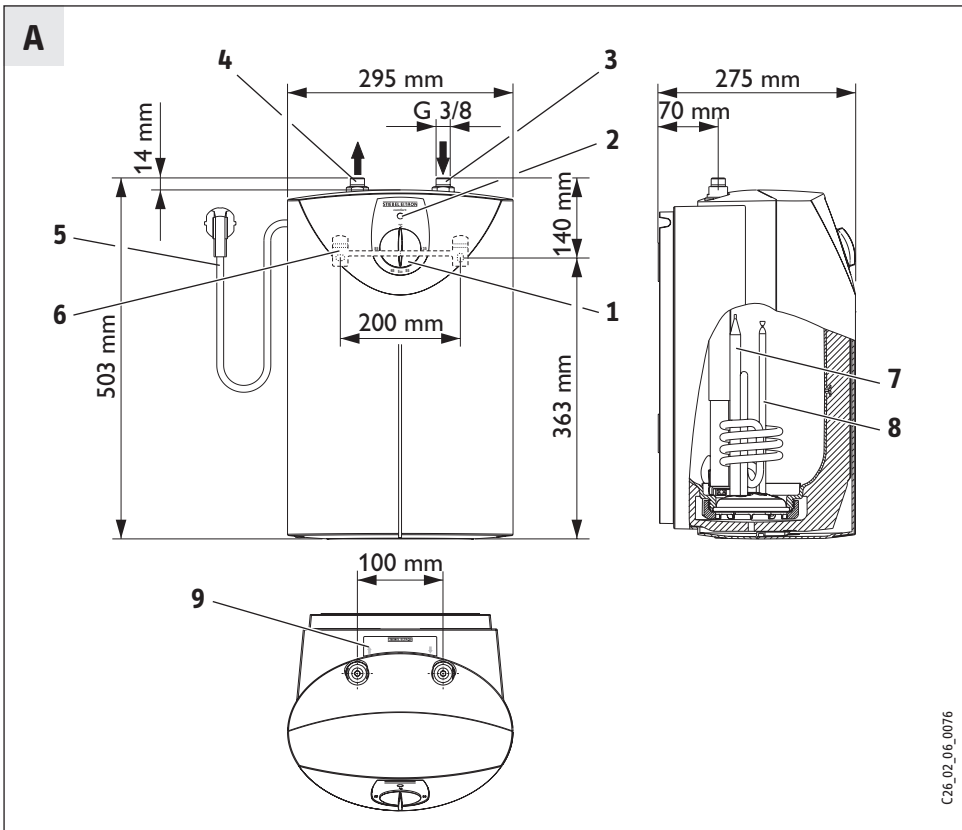

C26_02_06_0076

C26_02_06_0005

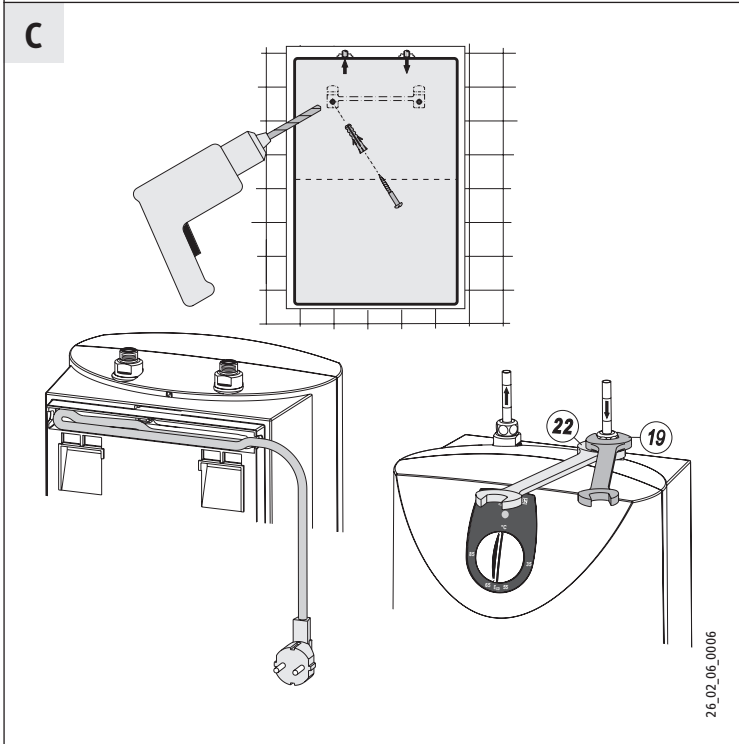

26_02_06_0006

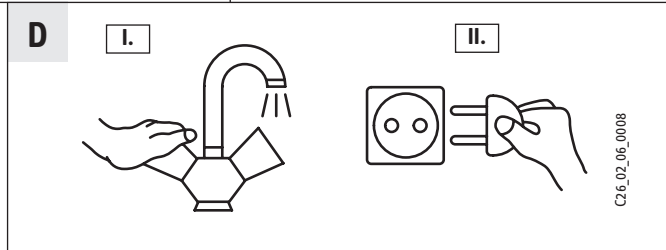

C26_02_06_0008

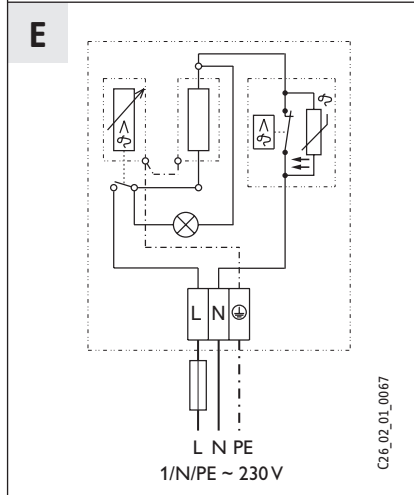

C26_02_01_0067

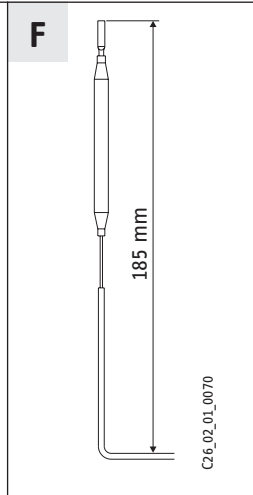

C26_02_01_0070

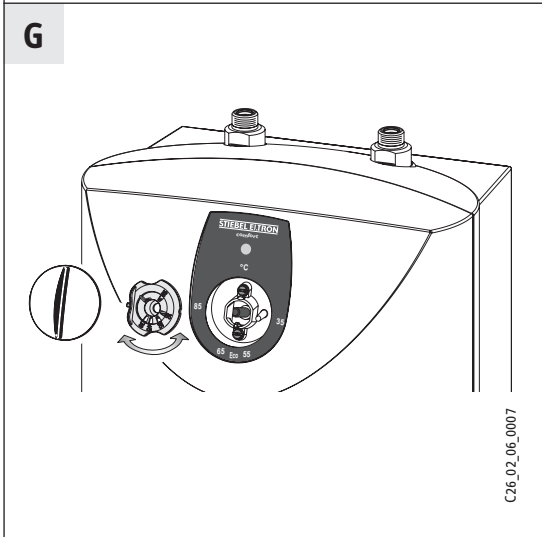

C26_02_06_0007

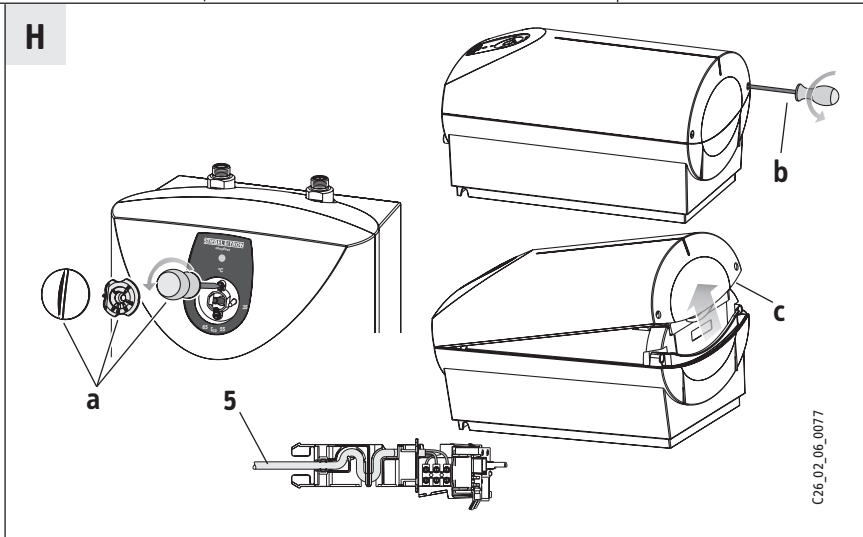

C26_02_06_0077



1. Operating Instructions for the user and engineer

1.1 Description of Unit

The open (pressure-less) water heater constantly maintains the water content at the pre-set temperature.

On heating, the expansion water drips through the outlet fitting.

Only fittings for open (pressureless) water heaters may be installed. We recommend Stiebel Eltron fittings: for order no. see 1.7 „Special accessories”.

The “**thermostat**” function (thermal separation) prevents heating of the tempering fitting in standby mode.

1.2 The most important points in brief

- Set the desired hot water temperature at the temperature selector (1)
- The unit is heating when the display (2) lights.

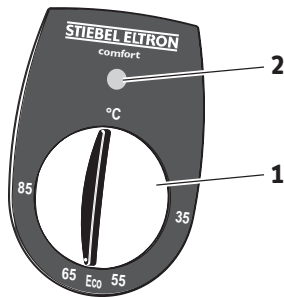

1.3 Operation

Temperature setting

°C = cold. On this setting, the unit, but not the fitting or water pipe, is protected from frost

Eco = recommended energy-saving setting (approx. 60 °C), low limescale formation

85 = max. temperature setting.

Note:

On request, the engineer can restrict the temperature on the unit (see 2.8 “First Use”) so that the temperature can be set anywhere up to the temperature limit.

Heating time:

If the entire water content is used, the heating time is that shown on the diagram.

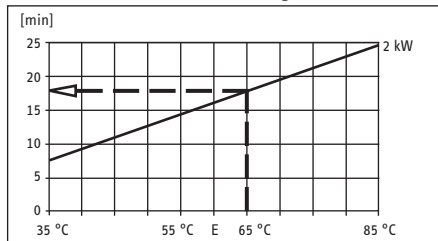

Example:

Temperature setting: **65 °C**
Heating time: **approx. 18 minutes**

Mixed water quantity:

Using the temperature, you set a mixed water quantity for e.g. 40 °C.

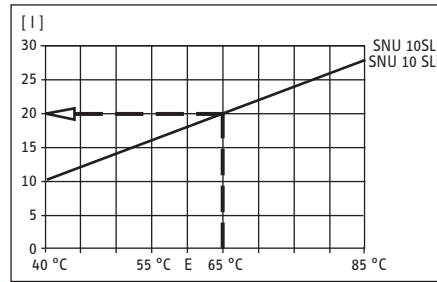

Example:

Temperature setting: 65 °C
Cold water feed: 15 °C
Mixed water quantity: approx. 20 l

1.4 Important Note



• The water heater must not be pressurized. Never block the fitting outlet and do not use a Perlator or hose with jet controller.

• If the temperature is set higher than 45 °C, very hot water can flow immediately!

• Keep children and the disabled (physical/mental) away from this unit unless they are supervised by a person responsible for their safety or have been given instructions on how to use it.

• Ensure that children do not adjust the temperature (to a high temperature) on the unit when playing - **Risk of scalding!**

• We recommend the use of the temperature restrictor set by the engineer, unless absolutely necessary otherwise.

• To avoid risk of accidental resetting of the protective temperature restrictor in the event of a fault, the unit must not be connected via a timer switch.

Limescale can block the outlet and hence pressurize the heater.

Signs of limescale are boiling sounds and reduced water flow. In this case have the unit and fitting descaled by an engineer

The thermostat knob may only be removed by an engineer.

All information in these Operating and Installation Instructions must be observed. The instructions contain important information for safety, operation and maintenance of the unit.

1.5 Care and Maintenance

To clean the unit, simply wipe with a damp cloth. Do not use abrasive or aggressive cleaning agents.



Maintenance work should only be performed by an engineer.

1.6 What to do if . . . ?

...there is no hot water:

Check the thermostat, plug and fuse.

...there is a boiling sound from the unit:

Have the unit and fitting descaled by an engineer.

...see also 3. „Fault repair by the user and engineer”.

If an engineer is called for a problem, to help him resolve this more quickly and efficiently, please give him the information below on the unit rating plate (9):

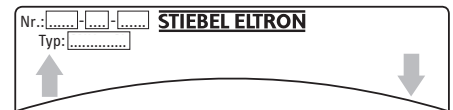

C26_02_06_0010

1.7 Special accessories

Stiebel Eltron order numbers:

• Two-handle tempering fittings

- for bathroom:

WST-W 07 44 27

WST 22 24 30

WSM 22 24 31

- for kitchen:

WST-K 07 44 28

WUT 22 24 32

WUM 22 24 33

• Single lever mixer fittings

- for bathroom:

MEW 22 24 39

- for kitchen:

MES 22 24 40

MESB 22 24 41

MESL 22 24 42



2. Installation Instructions for the engineer

Installation and electrical connection may only be carried out by an engineer in accordance with these instructions.

2.1 Unit Type **A**

- 1 Temperature selection knob
- 2 Indicator light
- 3 Cold water connection (blue)
- 4 Hot water connection (red)
- 5 Electrical connection line
- 6 Suspension rail
- 7 Protective pipe for protected temperature restrictor with reset function
- 8 Protective pipe for thermostat
- 9 Rating plate

2.2 Description of Unit

Open (pressureless) water heater for under-sink fitting, to supply a water tap, for heating cold water to EN 806.

Only fittings for open (pressureless) water heaters may be installed.

We recommend Stiebel Eltron fittings: for order no. see 1.7 „Special accessories”.

2.3 Technical Data

Current data on the rating plate.

Type	SNU 10 SL SNU 10 SLi
Nominal capacity	10 l
Design	open
Weight	4.6 kg
„thermostop“ - function	present
Heating power	see unit rating plate
Voltage	230 V
Flow rate, max.	10 l/min
Protection to EN 60529	IP 24 D
Connection line with plug	approx. 650 mm
Temperature setting range (fully adjustable)	approx. 35 °C - 85 °C

Table 1

2.4 Regulations and Conditions

- Perfect function and operating safety can only be guaranteed with the original Stiebel Eltron accessories and spare parts designed for the unit.
- The conditions of the local electricity supply company and competent water supply authority must be observed.
- The fitting outlet serves for ventilation. Do not block the outlet connector or fitting swivel arm. **Do not use a perlator or hose with jet regulator.**
- An earthed socket is required for connection of the unit which must remain freely accessible after installation of the unit. If the unit is permanently connected to the AC network (unit connection socket), it must be able to be isolated from the network via a separation gap of at least 3 mm in all poles. Installation with direct (fixed) electrical lines is not permitted.

2.5 Important Notes



If this unit is exposed to water pressure, the container may leak and cause water damage.

If the water connections on the unit are transposed, the unit will not function and the components may be damaged.

2.6 Installation Site **B**

The heater should be installed in a frost-free room, vertically with water connections at the top.

2.7 Unit Installation **C**

- Mount the suspension rail, position using mounting template. Select fixing materials according to the strength of the wall. Excess line length can be stored in the cable holder provided.
- Suspend the unit.
- Fit the water connections, set the flow rate (max. 10 l/min, see Description of Fitting). The colour marking of the fitting connections and heater must be allocated as follows:
 - right blue = cold water connection (3)
 - left red = hot water connection (4).

2.8 First Use **D**

(By the engineer only!)

- I. Open the hot water fitting or set the one-hand mixer to “warm” until the water emerges free from bubbles.
- II. Connect the electrical plug and select the temperature.



Danger of running dry!
If the sequence is changed, the protective temperature restrictor will trip in. In this case, add water and isolate the unit from the power supply briefly to reset the running dry protection.

III. Temperature setting restrictor **G** :

Only if the restricted temperature setting is required is the max. temperature set via the restrictor ring. To do this, pull off the thermostat knob and restrictor ring. Set the restrictor ring to the desired max. setting and push the thermostat knob back on.

IV. Remove protective film from controls.

Unit hand-over:

Explain to the user how the unit works and how to operate it. Point out any possible dangers (scalding). Give him these Installation and Operating Instructions for safe keeping.

2.9 Service Notes



Before all work, first isolate the unit from the power supply and remove the unit from the wall.

• Open unit **H** :

- a Pull off thermostat and temperature restrictor ring. Remove screw.
- b Lower locking bolt
- c Swivel housing cover aside and remove.

• Replace electrical power line:

To replace the connecting line use Stiebel Eltron part no. 02 06 71 (5, for order no. see 1.7 „Special Accessories”), or an H05VV-F3x1.0 line. Lay the connecting line in the guide **H** !

Circuit diagram **E**

• Positioning of thermostat sensor in protective pipe:

When replacing or removing the thermostat, insert the sensor 185 mm into the protective pipe **F** and attach below the earth plug.

• Drain unit:

The unit is drained via the connector.

• Descaling:

Remove heating flange, remove coarse scale by careful tapping, immerse heating element in limescale remover up to the flange plate.

• Checking earth conductor to BGV A3:

Disconnect the plug and remove the thermostat. Test at the thermostat fixing screw and earth contact of the connection line.

3. Fault Repair for the user and engineer

Fault	Cause	Rectification	
No hot water despite hot water fitting being fully open.	No power.	User / Engineer:	Check fuses on domestic system.
	Limescale on jet regulator.	User / Engineer:	Clean or replace jet regulator on fitting.
	Protective temperature restrictor (STB) has tripped.	Engineer:	Eliminate cause of fault (replace thermostat). Note: STB resets automatically when the unit power supply is switched off.
Boiling sound in heater.	Limescale in heater.	Engineer:	Descale unit.

Table 2

4. Environment and recycling



Recycling of obsolete appliances

 Appliances with this label must not be disposed off with the general waste. They must be collected separately and disposed off according to local regulations.

5. Guarantee

For guarantees please refer to the respective terms and conditions of supply for your country.



The installation, electrical connection and first operation of this appliance should be carried out by a qualified installer.

The company does not accept liability for failure of any goods supplied which accordance with the manufacturer's instructions.