

**1000 Ltr Vessel
Vertical**

SIDE VIEW

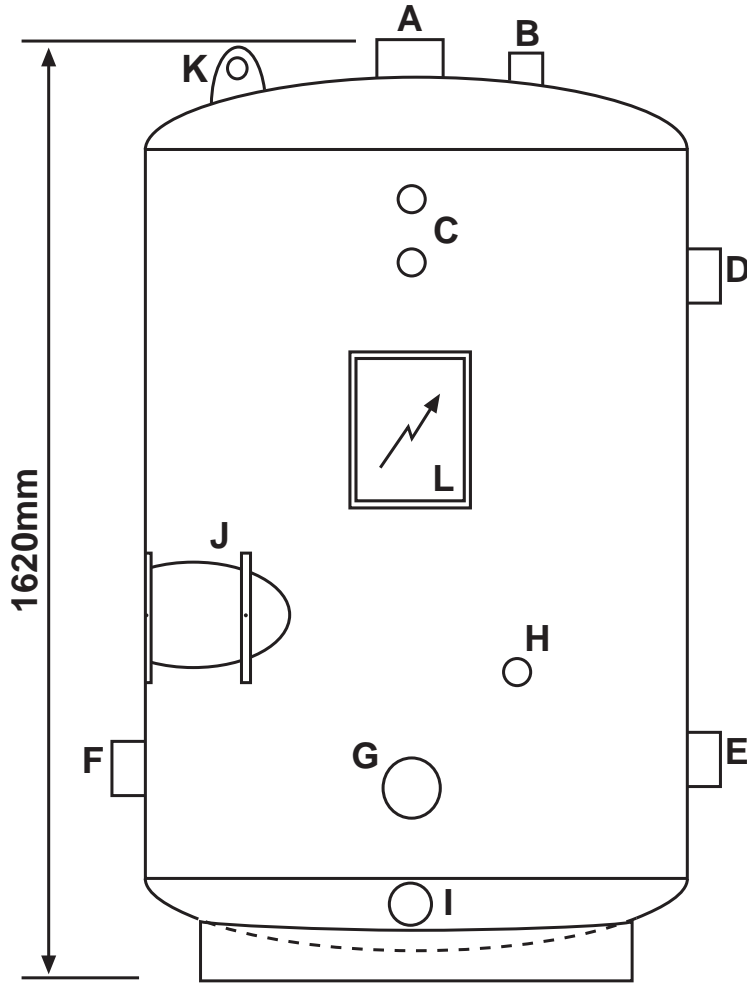

LEGEND	
A	50mm OUTLET
B	20mm SAFETY VALVE SOCKET
C	2 x 15mm GAUGE SOCKETS
D	50mm RETURN SOCKET
E	50mm INLET
F	50mm SPARE SOCKET
G	50mm ELEMENT SOCKET
H	20mm THERMOSTAT SOCKET
I	50mm DRAIN SOCKET
J	380mm ELLIPTICAL MANHOLE
K	LIFTING EYE
L	12kW STANDARD CONTROL PANEL

TOP VIEW

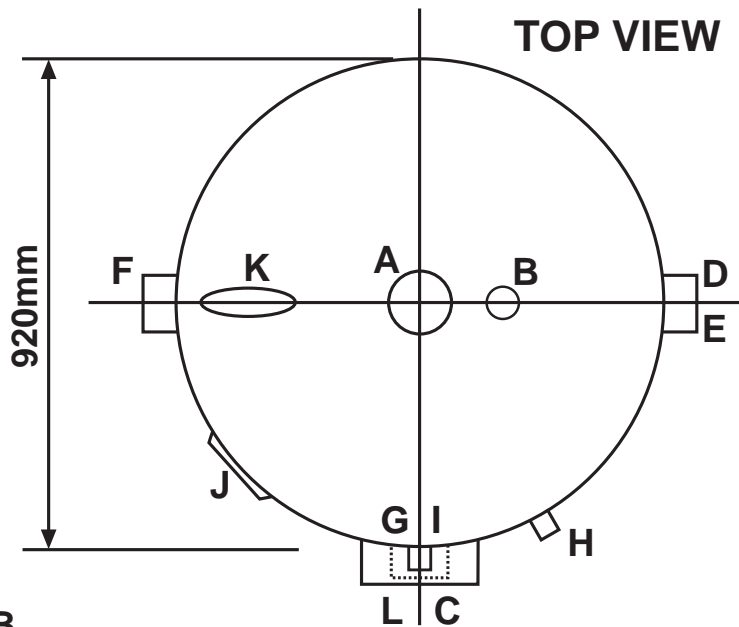

VESSEL	
ENDS	5mm
SHELL	5mm
W/PRESS	400 KPA
T/PRESS	600 KPA
INTERNAL	2 COATS SIGMARITE
EXTERNAL	2 COATS RED OXIDE
SAFETY (TP)	20mm INCLUDED
ACCESSORIES	THERMOSTAT / ELEMENT
GAUGES	EXCLUDED
LAGGING	INCLUDED

N.B.
DRAWING NOT TO SCALE
UNLAGGED DIMENSIONS

N.B.
DRAWING NOT TO SCALE
UNLAGGED DIMENSIONS

CUSTOMER

DESCRIPTION

APPROVED

1000L VERTICAL WATER HEATER

Approval Signature

FN:

DRAWING NO:

DATE: