

Element FCR 28 (120/180)

120 - Dual Circuit - 6kW / 12kW

180 - Dual Circuit - 9kW / 18kW

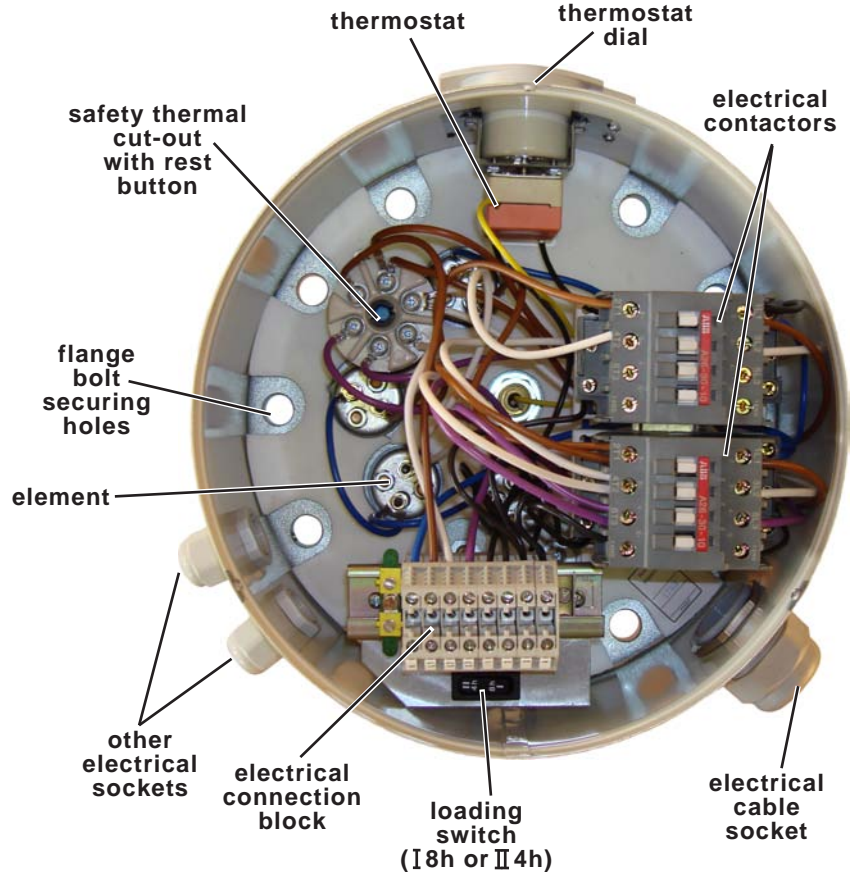
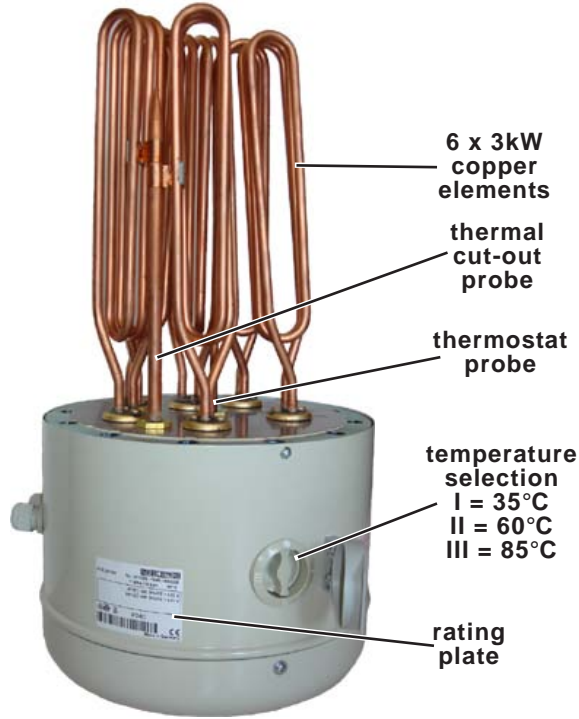

Counter Flange - GF 28

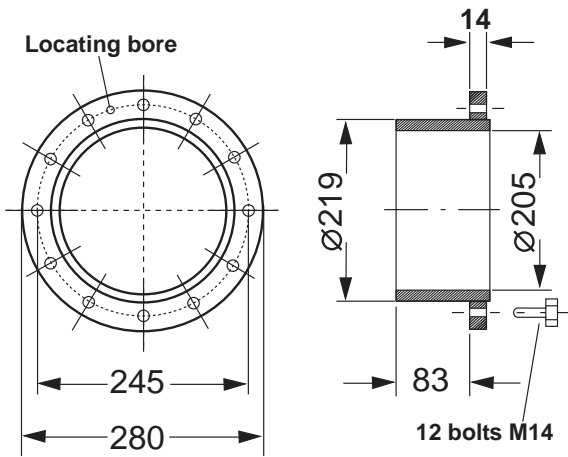

Heating Flange - FCR 28

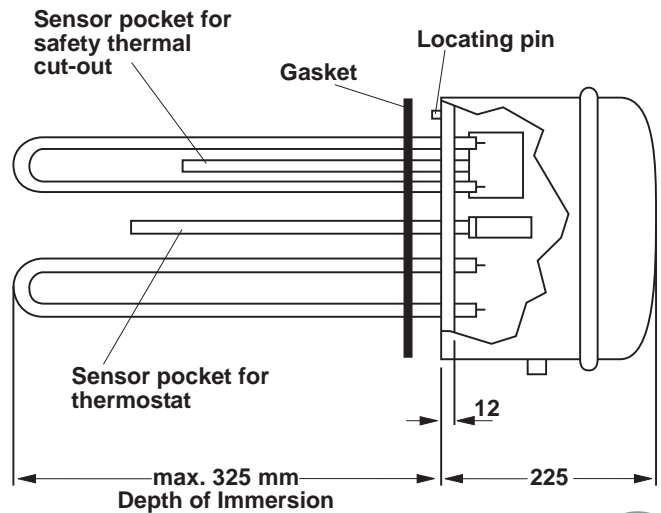

Electrical Data

Heating Flange FCR 28 /	Loading*	Voltage Ampage	Cable Size (3/N/PE)**	Circuit Breaker	Heating Elements
120	6 / 12kW	400V~17.3A	2.5mm ²	20amp	6 pieces
180	9 / 18kW	400V~26A	6mm ²	35amp	6 pieces

* Three phase power supply 380V~400V~415V.

** Cable 4 core + Earth (3/N/PE - 3 Lives, 1 Neutral & an Earth Wire).

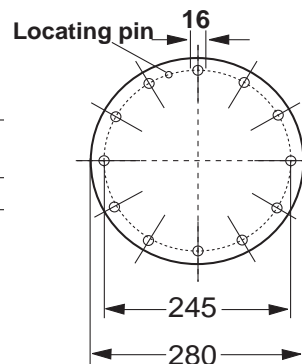

Compiled by;
Grant Mocké
Cell: 083 3389106