

**Element FCR 28/180**  
**Dual Circuit - 9kW / 18kW**

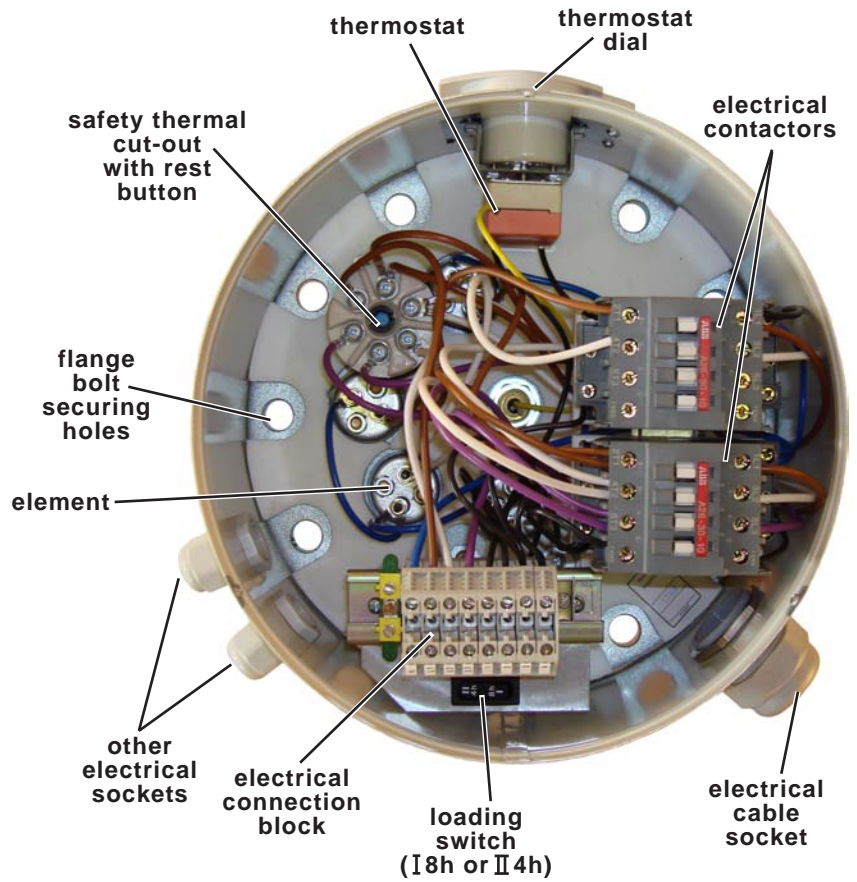

**Electrical Connection;**  
 18kW~400V~26A  
 Three Phase 30amp Circuit Breaker  
 6mm Cable 4 core + Earth (3/N/PE)  
 (3 Lives, 1 Neutral & an Earth Wire).

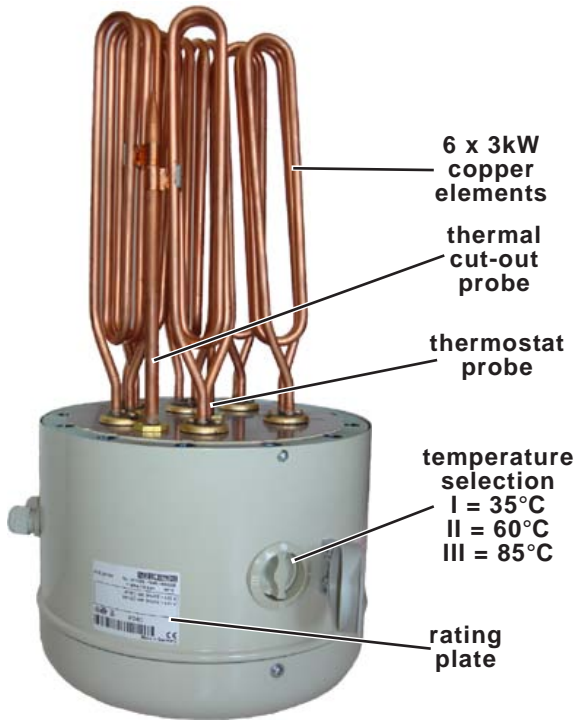
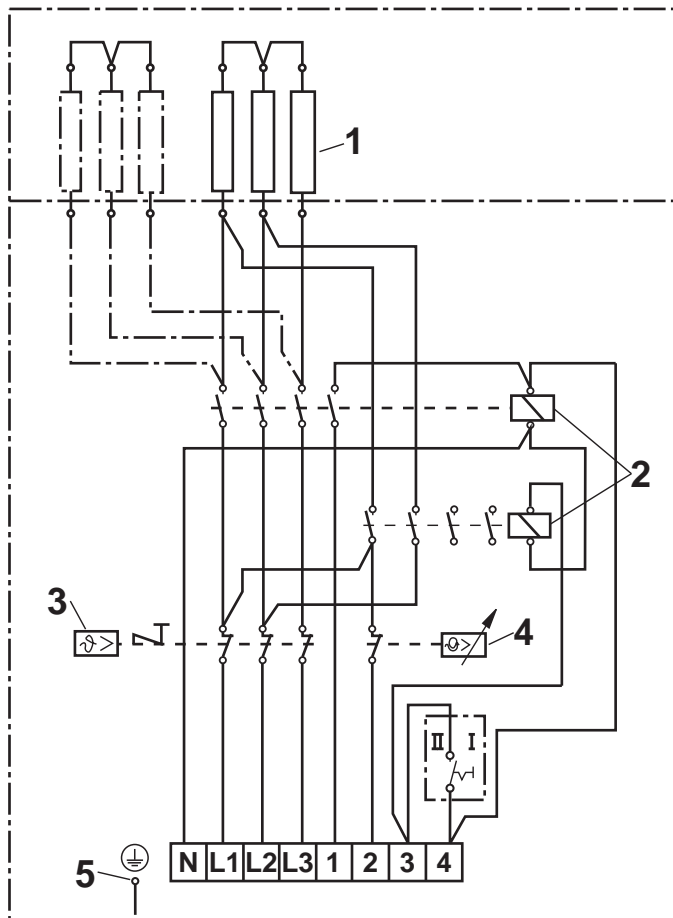

- 1.) Heating Elements.
- 2.) Contactor.
- 3.) Safety Thermal Cut-Out.
- 4.) Thermostat.
- 5.) Earth Wire Connection.
- 6.) Electricity Board Contact.
- 7.) Push Button for remote control of rapid heating.

**Dual Circuit Wiring**

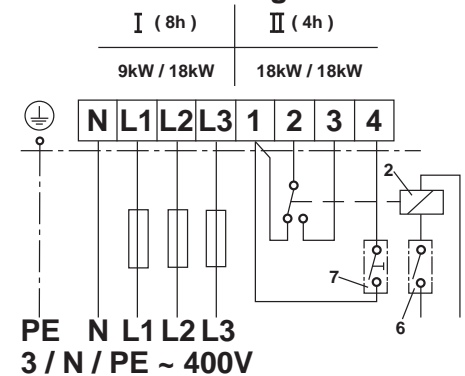

**Single Circuit Wiring**

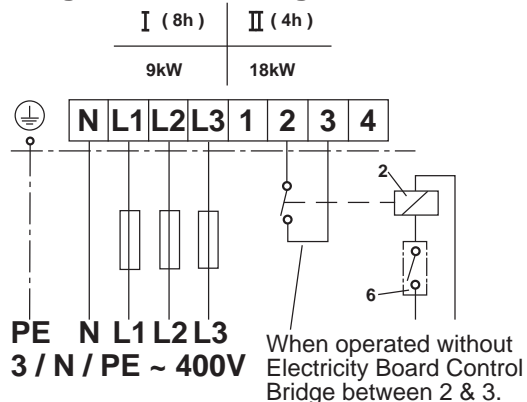

Compiled by:  
 Grant Mocke  
 Cell: 083 3389106